



WDM360TX



Heavy-Duty, Triple-Spindle Drink Mixer with Timer

Item # _____
 Model # _____
 Name _____
 SIS _____
 AIA _____



MAIN FEATURES

- Three independent, high-performance, 1 peak HP motors are user-replaceable for continued operation
- Each motor includes thermal protection to prolong motor life
- Electronic, 3-speed and pulse controls maintain speed under load for optimal performance – 15,000 / 18,000 / 21,000 RPM
- Fully enclosed actuators prevent mix from entering the housing
- Each unit includes 2 agitators for each spindle: One solid agitator for mixing hard ice creams and aerating for increased yield, and one butterfly agitator for softer ice creams and mix-ins
- Increased cup clearance: Slide cups into position without tilt
- Fully automatic, cup-activated, one-handed START/STOP operation
- 10-minute timers
- Heavy-duty, powder-coated die-cast steel housing
- Three stainless steel malt beverage cups included
- Limited One Year Warranty

ELECTRICAL

Voltage: 120
 Frequency: 60Hz
 Watts: 1125
 Amps: 3.3
 Plug Type: NEMA 5-15P ⓘ
 Cord Length: 5 feet



SALES FEATURES

Mix perfect shakes, one, two or three at a time, with the Waring® WDM360TX Heavy-Duty Triple-Spindle Drink Mixer with Timer. Automatic shutoff lets you attend to other tasks, while three independent 1 peak HP motors and ultra-aggressive agitators power through the coldest, hardest ice creams. Increased cup clearance helps you avoid spills while making creamy milkshakes or other frozen drinks.



@waringcommercial

©2019 Waring Commercial
 314 Ella T. Grasso Avenue, Torrington, CT 06790
 Tel. 800-492-7464 • Fax 860-496-9008

waringcommercialproducts.com

Heavy-Duty, Triple-Spindle Drink Mixer with Timer

WDM360TX



Heavy-Duty, Triple-Spindle Drink Mixer with Timer WDM360TX

INCLUDED ACCESSORIES



CAC20 Stainless Steel Malt Cup



CAC112 Solid Agitator (6 pack)



CAC123 Butterfly Agitator (6 pack)

DIMENSIONS

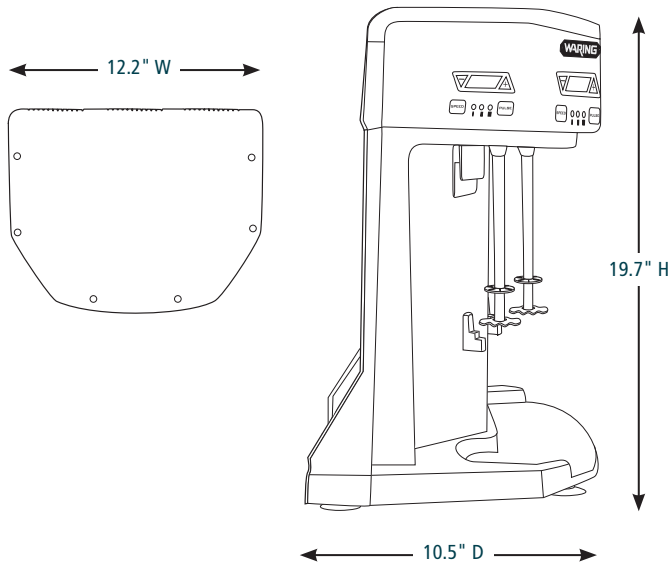
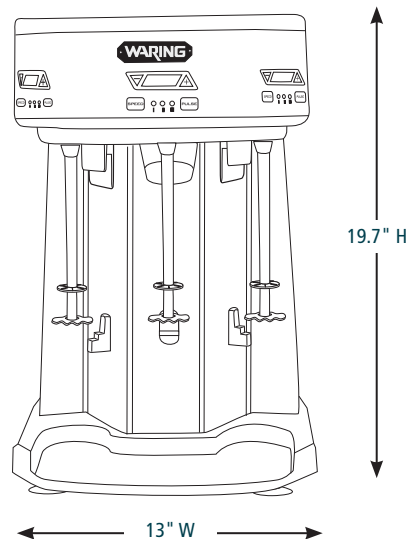

Out of Box Weight: 32.5 lb.

ORDERING INFORMATION	#STD. PKG.	GIFTBOX WEIGHT	CUBIC FEET	BOX DIMENSIONS L X W X H	UPC	CASE PKG.	MC WEIGHT	MC DIMENSIONS L X W X H	MBC
WDM3600TX – Heavy-Duty, Triple-Spindle Drink Mixer with Timer	1	37.07	2.4	15.1" x 13" x 22"	040072083310	1	38.5	16" x 13.4" x 22.8"	10040072083317



@waringcommercial

©2019 Waring Commercial
314 Ella T. Grasso Avenue, Torrington, CT 06790
Tel. 800-492-7464 • Fax 860-496-9008

waringcommercialproducts.com

19WC059596 / REV 01/19