

# 3M™ Water Filtration Products

SPEC# \_\_\_\_\_

application: **ICE**

QUANTITY \_\_\_\_\_

models:

## ICE120-S/ICE125-S



3M Purification Inc. Water Filtration Products Models ICE120-S and ICE125-S single cartridge water filtration systems help provide consistent high quality water for commercial ice by reducing the effects of sediment and chlorine taste and odor at flow rates up to 1.5 gpm (5.7 lpm). Built-in scale inhibition reduces the ability of calcium and magnesium to precipitate on the evaporator plates as hard scale.

- **ICE120-S** combines cyst, sediment and chlorine taste and odor reduction, while reducing the effects of chlorine corrosion and scale for up to 9,000 gallons (34,069 liters).
- **ICE125-S** combines chlorine taste and odor reduction with sediment and scale reduction from higher turbidity water, while reducing the effects of chlorine corrosion and scale for up to 10,000 gallons (37,854 liters).

### PRODUCT BENEFITS

- Effectively reduces sediment and chlorine taste and odor for better equipment protection and clearer, great tasting ice.
- Tested and verified by manufacturer's laboratory to Standard 53 for cyst reduction (HF20-S replacement cartridge).
- NSF Standard 42 and/or FDA CFR-21 compliant materials.
- Built-in scale inhibitor reduces lime scale build-up on evaporator plates as tested by 3M Purification.
- Valve-in-head design simultaneously shuts off and vents water, allowing for simple and virtually trouble-free cartridge change-outs without the need to shut off the upstream feed water.
- Sanitary Quick Change (SQC) encapsulated cartridge design allows for fast and easy cartridge change-outs with a 1/4 turn.
- 3/8" FNPT horizontal inlet and outlet ports allow direct or easily adaptable connections to existing plumbing lines.

### PRODUCT SPECIFICATIONS

Model Number	Part Number	Reduction Claims	Nominal Micron Rating	Capacity	Service Flow Rate	Application	Replacement Cartridge	Sizing
ICE120-S	56160-03	Cyst, Sediment, Chlorine Taste and Odor, Scale <sup>1</sup>	0.5	9,000 gallons (34,069 liters)	1.5 gpm (5.7 lpm)	Most Standard Water	HF20-S: 56151-03	Low Flow Cubers to 750 lbs. (340 kg) High Flow Cubers to 200 lbs. (91 kg) Flakers to 1,200 lbs. (544 kg)
ICE125-S	56160-04	Sediment, Chlorine Taste and Odor, Scale <sup>1</sup>	1.0	10,000 gallons (37,854 liters)	1.5 gpm (5.7 lpm)	Higher Turbidity Water	HF25-S: 56152-03	Low Flow Cubers to 750 lbs. (340 kg) High Flow Cubers to 200 lbs. (91 kg) Flakers to 1,200 lbs. (544 kg)

<sup>1</sup>Tested and verified by manufacturer's laboratory



# ICE120-S/ICE125-S

SPEC# \_\_\_\_\_

QUANTITY \_\_\_\_\_

MODEL NUMBER \_\_\_\_\_

PART NUMBER \_\_\_\_\_

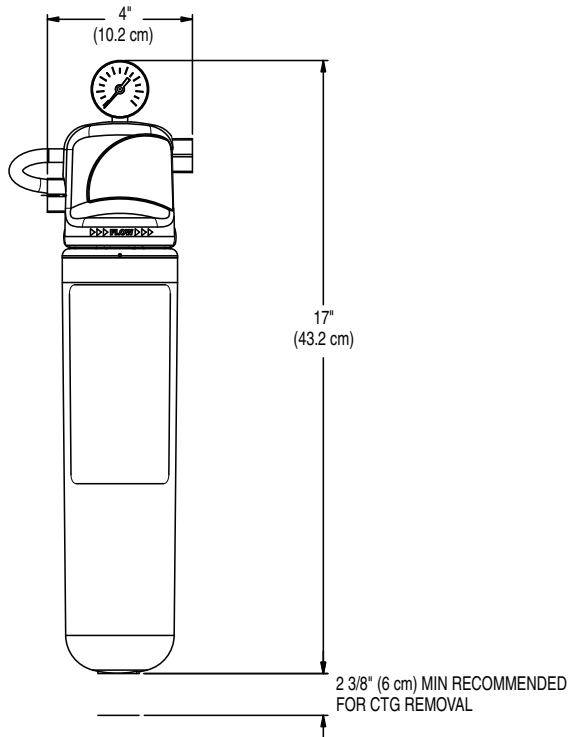

## ⚠ WARNING: To reduce the risk associated with the ingestion of contaminants:

- Do not use with water that is microbiologically unsafe or of unknown quality without adequate disinfection before or after the system. Systems certified for cyst reduction may be used on disinfected water that may contain filterable cysts. EPA Establishment #070595-CT-001

3M Purification Inc. recommends regularly scheduled maintenance and replacement of the filter cartridge(s) in order for the product to perform as advertised/sold. 3M Purification shall not be liable for system failures due to improper maintenance.

## LIMITED WARRANTY

3M Purification Inc. warrants this Product will be free from defects in material and manufacture for five (5) years from the date of purchase: The filter cartridge or filter membrane is warranted to be free from defects in material and manufacture for one (1) year. This warranty does not cover failures resulting from abuse, misuse, alteration or damage not caused by 3M Purification Inc. or failure to follow installation and use instructions. No warranty is given as to the service life of any filter cartridge or membrane as it will vary with local water conditions and water consumption. 3M PURIFICATION INC. MAKES NO OTHER WARRANTIES OR CONDITIONS, EXPRESS OR IMPLIED, INCLUDING, BUT NOT LIMITED TO, ANY IMPLIED WARRANTY OR CONDITION OF MERCHANTABILITY OR FITNESS FOR A PARTICULAR PURPOSE OR ANY IMPLIED WARRANTY OR CONDITION ARISING OUT OF A COURSE OF DEALING, CUSTOMER OR USAGE OF TRADE. If the Product fails to satisfy this Limited Warranty during the warranty period, 3M Purification Inc. will replace the Product or refund your Product purchase price. This warranty does not cover labor. The remedy stated in this paragraph is Customer's sole remedy and 3M Purification Inc.'s exclusive obligation. For additional information, see the entire Limited Warranty located in the product Installation and Operating Instruction Manual.

**Limitation of Liability:** 3M Purification Inc. will not be liable for any loss or damage arising from this 3M Purification Inc. product, whether direct, indirect, special, incidental, or consequential, regardless of the legal theory asserted, including warranty, contract, negligence or strict liability. Some states and countries do not allow the exclusion or limitation of incidental or consequential damages, so the above limitation or exclusion may not apply to you.

# 3M Purification Inc. Water Filtration Products

## PHYSICAL SPECIFICATIONS

- System includes a head assembly with integral mounting bracket, pressure gauge and a single cartridge filter.
- Inlet and outlet plumbing connections are 3/8" FNPT.
- System incorporates an internal automatic 1/4 turn shut-off valve.
- Filter cartridges are o-ring seal type.
- System maximum operating pressure of 125 psi (862 kPa) and operating temperature of 100°F (37.8°C).
- Recommended service flow rate is up to 1.5 gpm (5.7 lpm).
- Filter cartridges incorporate carbon block filtration medium and scale inhibitor.
- System materials are NSF Standard 42 and/or FDA CFR-21 compliant.
- Cartridges are sanitary in design, requiring no contact with the filter media during cartridge change-out.
- Filter cartridges require no pre-activation.
- NSF Performance Data Sheet (PDS) is included.
- Shipping weight: 19 lbs. (8.6 kg) per case.
- Case quantity: 6.

## IMPORTANT: INSTALLATION TIPS

**These installation tips are for informational purposes only and are not intended to be used as actual installation instructions. CAUTION: To reduce the risk associated with property damage due to water leakage:**

- **Read and follow** Use Instructions before installation and use of this system.
- Installation and use **MUST** comply with all state and local plumbing codes.
- **Protect from freezing**, remove filter cartridge when temperatures are expected to drop below 40°F (4.4°C).
- **Do not install on hot water supply lines.** The maximum operating water temperature of this filter system is 100°F (37.8°C).
- **Do not install** if water pressure exceeds 125 psi (862 kPa). If your water pressure exceeds 80 psi (552 kPa), you must install a pressure limiting valve. Contact a plumbing professional if you are uncertain how to check your water pressure.
- **Do not install** where water hammer conditions may occur. If water hammer conditions exist you must install a water hammer arrester. Contact a plumbing professional if you are uncertain how to check for this condition.
- The disposable filter cartridge **MUST** be replaced every 12 months, at the rated capacity or if a noticeable reduction in flow rate occurs.

# 3M

3M Purification Inc.  
400 Research Parkway  
Meriden, CT 06450 U.S.A.  
Toll Free: 1.800.243.6894  
Worldwide: 203.237.5541  
Fax: 203.630.4530  
www.3mpurification.com



Visit [www.nsf.org](http://www.nsf.org) for the claims associated with products that are NSF listed.

3M is a trademark of 3M Company.  
NSF is a trademark of NSF International.  
© 2011 3M Company. All rights reserved.  
LITFS288 0811B  
70-0201-9415-8  
Please recycle. Printed in U.S.A.