



Gas Regulator Included

# COMMERCIAL GAS GRIDDLE Manual & Thermostat Control



Model	Burners
GR-24/ GR-24-T	2
GR-36/ GR-36-T	3
GR-48/ GR-48-T	4

COUNTERTOP COOKING

The Entrée Gas Counter Griddle is available in both Manual or Thermostatic Control.

The efficient 3/4" griddle plate offers the thickness of even heat distribution along with Entrée's "quick on" turning the burners on when the probes sense temperature drop. This gives you important quick temperature recovery when cooking. The result is faster cook times, greater moisture retention, higher product yield — you serve a higher quality, moist product.

It is available in 24", 36" and large 48" widths and covers complete parts and labor 1 year warranty. Units are shipped for natural gas but are easily converted to LP (propane) gas with the LP conversion kit that is included.

All Griddles carry ETL gas and sanitation approvals that pass US gas and sanitation requirements for use in restaurants.

## STANDARD FEATURES

- High Performance and Efficient 30,000 BTU Stainless Steel U style burners provide flame every 6" on the griddle surface
- 3/4" Highly Polished griddle plate providing even heat distribution
- 4" High Backsplash and Sidesplash fully welded to the griddle
- Double wall construction with insulated side panels
- Extended cool to touch front edge
- Thermostatic Griddle with Piezo Ignition available with 200 °F to 450 °F temperature range
- Wide 3 1/4" front grease trough
- Removable, easy to clean stainless grease catch pan
- Large temperature knobs with set screws
- Pilots with front access
- Adjustable non skid Stainless Steel legs

Warranty: Entrée's exclusive parts and labor FUSS warranty takes affect from 1 year after end user purchase.





# DETAILS AND DIMENSIONS

- A pressure regulator is provided with this unit.  
Natural Gas 4.0" W.C.  
Propane Gas 10.0" W.C.
- Gas connection is 3/4" NPT (19mm) rear gas connection.
- All equipment is supplied for Natural Gas, an LP conversion kit is also provided.

## All Manual Units

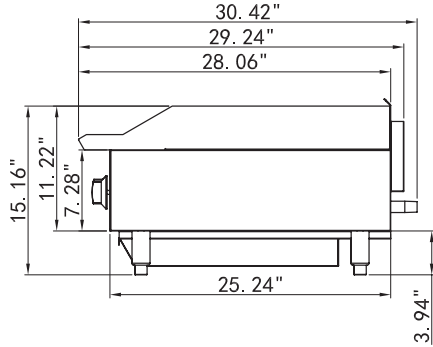

## GR-24/ GR-24T

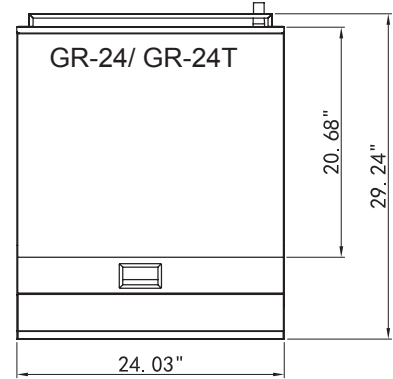
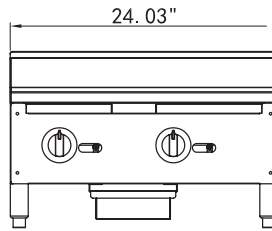

## All Thermostatic Units

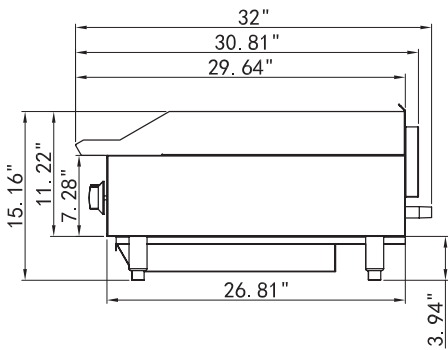

## GR-36/ GR-36T

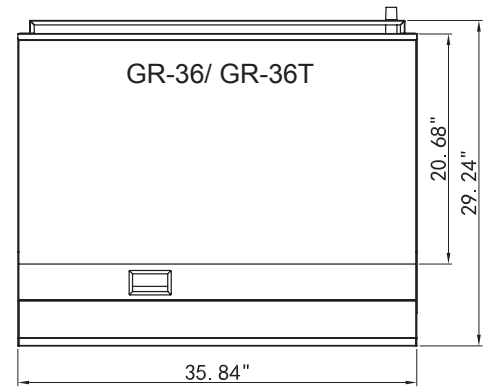
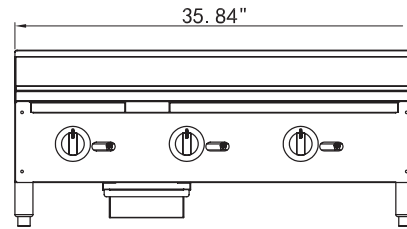

## GR-48/ GR-48T

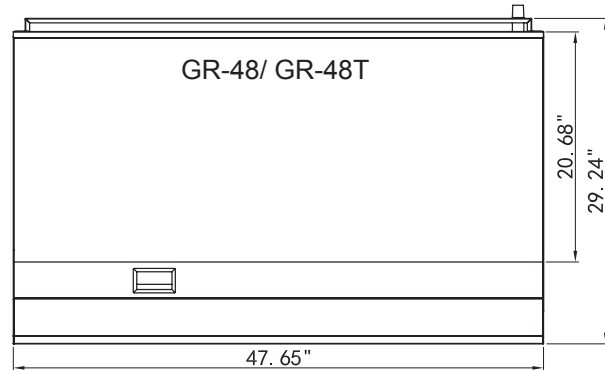
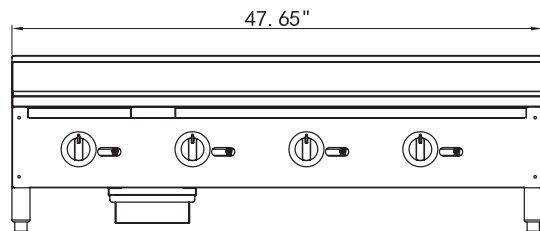

	Model	Burners	Cooking Area		Plate Thickness	Dimensions			BTU's (per burner)	Total BTU's	Crated Weight (lbs)
			L	W		W	D	H			
Manual Units	GR-24	2	20.68	23.97	3/4"	24.03	29.24	15.16	30,000	60,000	198
	GR-36	3	20.68	35.78	3/4"	35.84	29.24	15.16	30,000	90,000	274
	GR-48	4	20.68	47.59	3/4"	47.65	29.24	15.16	30,000	120,000	352
Thermostatic Units	GR-24-T	2	20.68	23.97	3/4"	24.03	29.24	15.16	30,000	60,000	198
	GR-36-T	3	20.68	35.78	3/4"	35.84	29.24	15.16	30,000	90,000	274
	GR-48-T	4	20.68	47.59	3/4"	47.65	29.24	15.16	30,000	120,000	352