



TRUE FOOD SERVICE EQUIPMENT, INC.

2001 East Terra Lane • P.O. Box 970 • O'Fallon, Missouri 63366
 (636)240-2400 • Fax (636)272-2408 • (800)325-6152 • Intl Fax# (001)636-272-7546
 Parts Dept. (800)424-TRUE • Parts Dept. Fax# (636)272-9471 • www.truemfg.com

Project Name: _____

Location: _____

Item #: _____ Qty: _____

Model #: _____

A/A #

S/S #

Model:
TUC-67F

Deep Undercounter:
Solid Door Freezer



TUC-67F

- ▶ True's deep undercounter units feature the combined advantage of undercounter placement with deeper refrigerated storage.
- ▶ True's deep undercounter units are designed with enduring quality that protects your long term investment.
- ▶ Designed using the highest quality materials and components to provide the user with colder product temperatures, lower utility costs, exceptional food safety and the best value in today's food service marketplace.
- ▶ Extra large evaporator coil balanced with higher horsepower compressor and large condenser maintains -10°F (-23.3°C). Ideally suited for both frozen foods and ice cream.
- ▶ All stainless steel front, top and ends. Matching aluminum finished back.
- ▶ NSF approved, white aluminum interior liner. 300 series stainless floor with coved corners.
- ▶ Heavy duty PVC coated wire shelves.
- ▶ Automatic defrost system time-initiated, time-terminated.
- ▶ Foamed-in-place, high density polyurethane insulation (CFC free).

ROUGH-IN DATA

Specifications subject to change without notice.
 Chart dimensions rounded up to the nearest 1/8" (millimeters rounded up to next whole number).

Model	Doors	Capacity (Cu. Ft.) (liters)	Shelves	Cabinet Dimensions (inches) (mm)			HP	Voltage	Amps	NEMA Config.	Cord Length (total ft.) (total m)	Crated Weight (lbs.) (kg)
				L	D†	H*						
TUC-67F	2	20.6 584	4	67¼ 1709	32¼ 820	29¾ 756	¾	115/60/1	11.7	5-15P	7 2.13	395 180

† Depth does not include 1" (26 mm) for rear and ¼" (7 mm) for front bumpers.
 * Height does not include 6¼" (159 mm) for castors or 6" (153 mm) for optional legs.

	<p>APPROVALS:</p>	<p>AVAILABLE AT:</p>
<p>Printed in U.S.A.</p>		

Model:
TUC-67F

Deep Undercounter: Solid Door Freezer



STANDARD FEATURES

DESIGN

- True's commitment to using the highest quality materials and oversized refrigeration systems provides the user with colder product temperatures, lower utility costs, exceptional food safety and the best value in today's food service marketplace.

REFRIGERATION SYSTEM

- Factory engineered, self-contained, capillary tube system using environmentally friendly (CFC free) R404A refrigerant.
- Oversized, factory balanced refrigeration system with guided airflow to provide uniform product temperatures.
- Extra large evaporator coil balanced with higher horsepower compressor and large condenser; maintains -10°F (-23.3°C). Ideally suited for both frozen foods and ice cream.
- Sealed, cast iron, self-lubricating evaporator fan motor(s) and larger fan blades give True undercounter units a more efficient, low velocity, high volume airflow design. This unique design ensures faster temperature recovery and shorter run times in the busiest of food service environments.
- Condensing unit is accessed from behind front grill; slides out for easy maintenance.
- Automatic defrost system time-initiated, time-terminated.

CABINET CONSTRUCTION

- Exterior - stainless steel front, top and ends. Matching aluminum finished back.
- Interior - attractive, NSF approved, white aluminum liner. 300 series stainless steel floor with covered corners.
- Insulation - entire cabinet structure and solid door(s) are foamed-in-place using high density, CFC free, polyurethane insulation.
- 5" (127 mm) diameter stem castors - locks provided on front set. 36" (915 mm) work surface height.

DOORS

- Stainless steel exterior with white aluminum liner to match cabinet interior.

- Each door fitted with 12" (305 mm) long recessed handle that is foamed-in-place with a sheet metal interlock to ensure permanent attachment.
- Positive seal door(s) swing within cabinet dimensions.
- Magnetic door gasket(s) of one piece construction, removable without tools for ease of cleaning.

SHELVING

- Four (4) adjustable, heavy duty PVC coated wire shelves 27½" L x 16" D (699 mm x 407 mm). Four (4) chrome plated shelf clips included per shelf.
- Shelf support pilasters made of same material as cabinet interior; shelves are adjustable on ½" (13 mm) increments.

MODEL FEATURES

- Evaporator is epoxy coated to eliminate the potential of corrosion.
- NSF-7 compliant for open food product.

ELECTRICAL

- Unit completely pre-wired at factory and ready for final connection to a 115/60/1 phase, 15 amp dedicated outlet. Cord and plug set included.



115/60/1
NEMA-5-15R

OPTIONAL FEATURES/ACCESSORIES

Upcharge and lead times may apply.

- 6" (153 mm) standard legs.
- 6" (153 mm) seismic/flanged legs.
- 2½" (64 mm) diameter castors.
- 3" (85 mm) diameter castors.
- Single oversheff.
- Double oversheff.
- 32⅞" (816 mm) deep, ½" (13 mm) thick, white polyethylene cutting board. Requires "L" brackets.
- 32⅞" (816 mm) deep, ½" (13 mm) thick, composite cutting board. Requires "L" brackets.
- Half bun tray rack(s). Each holds up to eleven 18"L x 26"D (458 mm x 661 mm) sheet pans (sold separately).
- Heavy duty, 16 gauge tops.
- Heavy duty package - 16 gauge tops, 20 gauge door, sides and back with stainless interior.

- Exterior round digital temperature display (factory installed).
- Remote cabinets (condensing unit supplied by others; system comes standard with 404A expansion valve and requires R404A refrigerant). Consult factory technical service department for BTU information.

PLAN VIEW

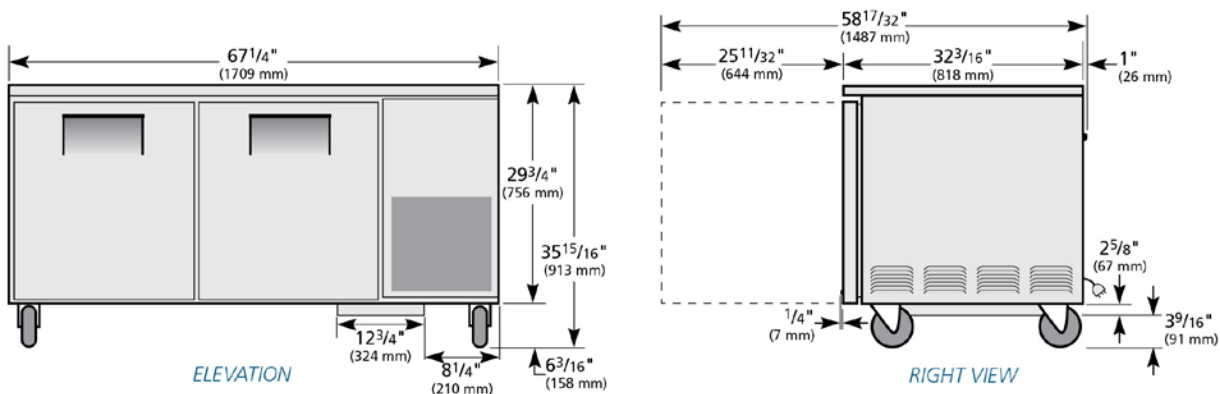

WARRANTY

One year warranty on all parts and labor and an additional 4 year warranty on compressor. (U.S.A. only)

METRIC DIMENSIONS ROUNDED UP TO THE NEAREST WHOLE MILLIMETER

SPECIFICATIONS SUBJECT TO CHANGE WITHOUT NOTICE



Model	Elevation	Right	Plan	3D	Back
TUC-67F	TFPY11E	TFPY42S	TFPY11P	TFPY113	

TRUE FOOD SERVICE EQUIPMENT

2001 East Terra Lane • P.O. Box 970 • O'Fallon, Missouri 63366 • (636)240-2400 • Fax (636)272-2408 • (800)325-6152 • Intl. Fax# (001)636-272-7546 • www.truefmfg.com