



**TRUE FOOD SERVICE EQUIPMENT, INC.**

St. Charles Industrial Center • P.O. Box 970 • O'Fallon, Missouri 63366  
 (636)240-2400 • FAX (636)272-2408 • (800)325-6152 • www.truemfg.com  
 Parts Dept. (800)424-TRUE • Parts Dept. FAX# (636)272-9471

Project Name: \_\_\_\_\_

A/A #

Location: \_\_\_\_\_

Item #: \_\_\_\_\_ Qty: \_\_\_\_\_

SIS #

Model #: \_\_\_\_\_

Model:  
**TSSU-60-12**

**Food Prep Table:**  
*Solid Door Sandwich/Salad Unit*



**TSSU-60-12**

- ▶ True's salad/sandwich units are designed with enduring quality that protects your long term investment.
- ▶ Oversized, environmentally friendly (134A) forced-air refrigeration system holds 33°F to 41°F (.5°C to 5°C).
- ▶ Complies with and listed under ANSI/NSF-7-1997-6.3.
- ▶ All stainless steel front, top and cabinet ends. Matching aluminum finished back.
- ▶ Stainless steel, patented, foam insulated lid and hood maintains uniform pan temperature, locks in freshness and minimizes condensation. Removable for easy cleaning.
- ▶ 11<sup>3</sup>/<sub>4</sub>" (299 mm) deep full length removable cutting board included. Sanitary, high-density, NSF approved white polyethylene provides tough preparation surface.
- ▶ Foamed-in-place, high density polyurethane insulation (CFC free).
- ▶ Heavy duty PVC coated wire shelves.

**ROUGH-IN DATA**

Chart dimensions rounded up to the nearest 1/8" (millimeters rounded up to next whole number). Specifications subject to change without notice.

Model	Solid Doors	Capacity (Cu. Ft.) (liters)	# of Shelves	# of Pans (top)	Cabinet Dimensions (inches) (mm)			HP	Voltage	Amps	NEMA Config.	Cord Length (total ft.) (total m)	Crated Weight (lbs.) (kg)
					L	D†	H*						
TSSU-60-12	2	15.5 439	4	12	60 <sup>3</sup> / <sub>8</sub>	30 <sup>1</sup> / <sub>8</sub>	36 <sup>3</sup> / <sub>4</sub>	1/3	115/60/1	7.8	5-15P	7	345
					1534	766	934	1/3	230-240/50/1	4.2	▲	2.13	157

† Depth does not include 1" (26 mm) for rear bumpers.

▲ Plug type varies by country.

\* Height does not include 6 1/4" (159 mm) for castors or 6" (153 mm) for optional legs.



**APPROVALS:**

Model:  
**TSSU-60-12**

**Food Prep Table:**  
*Solid Door Sandwich/Salad Unit*



**STANDARD FEATURES**

**DESIGN**

- True's commitment to using the highest quality materials and oversized refrigeration systems provides the user with colder product temperatures, lower utility costs, exceptional food safety and the best value in today's food service marketplace.

**REFRIGERATION SYSTEM**

- Factory engineered self-contained, capillary tube system using environmentally friendly (CFC free) 134A refrigerant.
- Oversized, factory balanced refrigeration system with guided airflow to provide uniform temperature in food pans and cabinet interior.
- Forced-air design holds 33°F to 41°F (5°C to 5°C) product temperature in food pans and cabinet interior. Complies with and listed under ANSI/NSF-7-1997-6.3.
- Sealed, cast iron, self-lubricating evaporator fan motors and larger fan blades give True sandwich/salad units a more efficient low velocity, high volume airflow design.
- Evaporator is epoxy coated to eliminate the potential of corrosion.
- Condensing unit access in back of cabinet, slides out for easy maintenance.

**CABINET CONSTRUCTION**

- Exterior - stainless steel front, top and cabinet ends. Matching aluminum finished back.
- Interior - attractive, NSF approved, white aluminum liner. 300 series stainless floor with coved corners.
- Insulation - entire cabinet structure and solid doors are foamed-in-place using high density, CFC free, polyurethane insulation.
- 5" (127 mm) diameter stem castors - locks provided on front set. 36" (915 mm) work surface height.

**DOORS**

- Stainless steel exterior with white aluminum liner to match cabinet interior.
- Positive seal self-closing doors with 90° stay open feature. Doors swing within cabinet dimensions.
- Each door fitted with 12" (305 mm) long recessed handle that is foamed-in-place with a sheet metal interlock to insure permanent attachment.
- Magnetic door gaskets of one piece construction, removable without tools for ease of cleaning.

**SHELVING**

- Four (4) adjustable, heavy duty PVC coated wire shelves 27<sup>1</sup>/<sub>2</sub>" L X 16" D (699 mm x 407 mm). Four (4) chrome plated shelf clips included per shelf.
- Shelf support pilasters made of same material as cabinet interior; shelves are adjustable on 1/2" (13 mm) increments.

**MODEL FEATURES**

- 11<sup>3</sup>/<sub>4</sub>" (299 mm) deep full length removable cutting board. Sanitary, high-density, NSF approved white polyethylene provides tough preparation surface.
- Stainless steel, patented, foam insulated lid and hood keep pans' temperature cooler, lock in freshness and minimize condensation. Removable for easy cleaning.
- Comes standard with 12 (1/6 size) 6<sup>7</sup>/<sub>8</sub>" L x 6<sup>1</sup>/<sub>4</sub>" W x 4" D (175 mm x 159 mm x 102 mm) clear polycarbonate, NSF approved, food pans in countertop prep area. Also accommodates 6" (153 mm) and 8" (204 mm) deep food pans.
- Countertop pan opening designed to fit varying size pan configurations with available pan divider bars. Varying size pans supplied by others.
- NSF-7 compliant for open food product.

**ELECTRICAL**

- Unit completely pre-wired at factory and ready for final connection to a 115/60/1 phase - 15 amp dedicated outlet. Cord and plug set included.



115/60/1  
NEMA-5-15R

**OPTIONAL FEATURES/ACCESSORIES**

Upcharge and lead times may apply.

- 230 - 240V / 50 Hz.
- 6" (153 mm) standard legs.
- 6" (153 mm) seismic/flanged legs.
- 2<sup>1</sup>/<sub>2</sub>" (64 mm) diameter castors.
- Additional shelves.
- Basic overshelf.
- Sandwich/salad service shelf.
- Single utility shelf.
- Double utility shelf.
- Sneezeguard.
- 19" (483 mm) deep, 1/2" (13 mm) thick, white polyethylene cutting board. Requires "L" brackets.
- 19" (483 mm) deep, 3/4" (20 mm) thick, white polyethylene cutting board. Requires "L" brackets.
- 11<sup>3</sup>/<sub>4</sub>" (299 mm) deep, 1/2" (13 mm) thick, composite cutting board. Requires "L" brackets.
- 19" (483 mm) deep, 1/2" (13 mm) thick, composite cutting board. Requires "L" brackets.
- Crumb catcher. Requires crumb catcher cutting board for proper installation.
- Pan dividers.
- ADA compliant model with 34" (864 mm) work surface height.
- Remote cabinets (condensing unit supplied by others), consult factory technical service department for BTU information.

**PLAN VIEW**

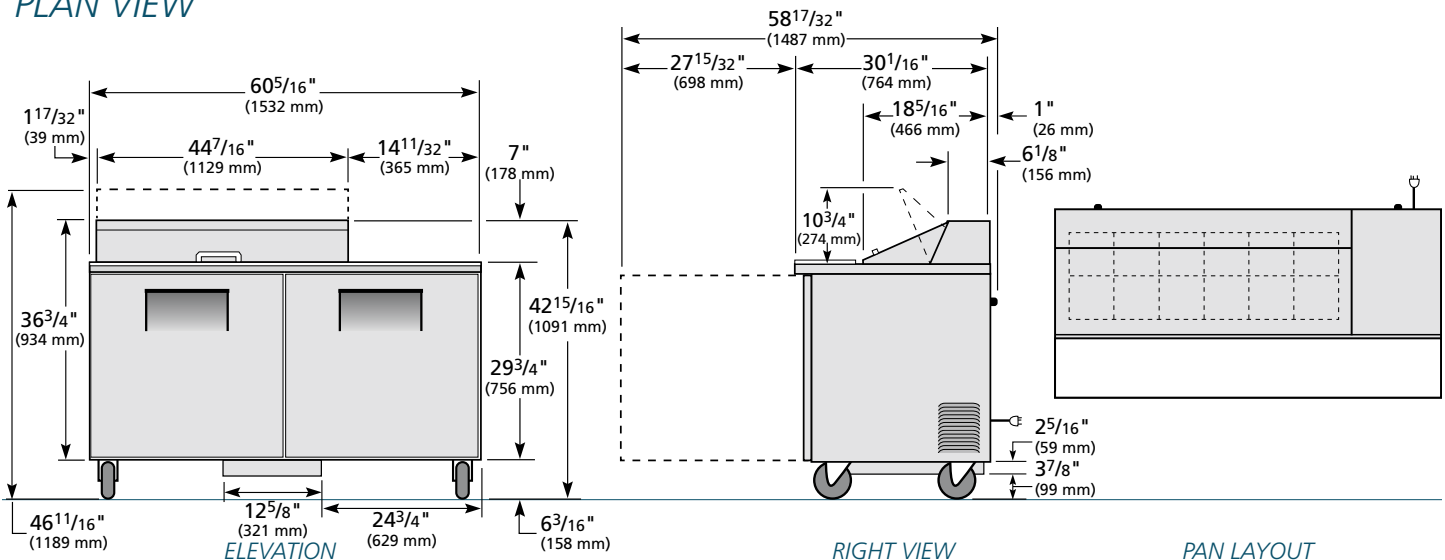

**WARRANTY**  
One year warranty on all parts & labor and an additional 4 year warranty on compressor. (U.S.A. only)

METRIC DIMENSIONS ROUNDED UP TO THE NEAREST WHOLE MILLIMETER  
SPECIFICATIONS SUBJECT TO CHANGE WITHOUT NOTICE

	Model	Elevation	Right	Plan	3D
	TSSU-60-12-ADA	TFNX09E	TFNX08S	TFNY07P	TFNX093

**TRUE FOOD SERVICE EQUIPMENT**