



**TRUE FOOD SERVICE
EQUIPMENT, INC.**

2001 East Terra Lane • P.O. Box 970 • O'Fallon, Missouri 63366
(636)240-2400 • Fax (636)272-2408 • (800)325-6152 • Intl Fax# (001)636-272-7546
Parts Dept. (800)424-TRUE • Parts Dept. Fax# (636)272-9471 • www.truemfg.com

Project Name: _____

Location: _____

Item #: _____ Qty: _____

Model #: _____

A/A #

SIS #

Model:
THDC-8

Horizontal Dipping Cabinet:
Freezer



THDC-8

- ▶ True's horizontal ice cream dipping cabinets are uniquely designed to provide the user maximum functional reliability with the flexibility to both store and serve ice cream product.
- ▶ Cold wall refrigeration system. Maintains -10°F to +8°F (-23.3°C to -13.3°C).
- ▶ Patented reversing condenser fan motors. Fan motors reverse during defrost off cycles to help keep condenser coil free from dirt, dust and debris. Keeping coils clean optimizes the unit's performance providing colder holding temperatures and increased energy efficiency. Regularly scheduled thorough cleaning of coils still recommended.
- ▶ Designed to hold nineteen (19) 9½" (242 mm diameter, 3 gallon (12 L) ice cream containers.
- ▶ Dual access, removable lids.
- ▶ NSF-7 compliant for open food product.
- ▶ Entire cabinet structure is foamed-in-place using Ecomate. A new, innovative, high density, polyurethane insulation that has zero ozone depletion potential (ODP) and zero global warming potential (GWP).

ROUGH-IN DATA

Specifications subject to change without notice.
Chart dimensions rounded up to the nearest 1/8" (millimeters rounded up to next whole number).

Model	Lids	Capacity			Cabinet Dimensions (inches) (mm)			HP	Voltage	Amps	NEMA Config.	Cord Length (total ft.) (total m)	Crated Weight (lbs.) (kg)	
		(Cu. Ft.) (liters)	3 Gallon (12 Liter) Cans		L	D	H*							
THDC-8	4	16.1 456	19	Display	11	54¼ 1378	30¾ 782	35 889	1/3	115/60/1	5.7	5-15P	9 2.74	370 168
			Total	Storage	8									

* Height does not include 3/8" (23 mm) for handles.

	<p>APPROVALS:</p>	<p>AVAILABLE AT:</p>
<p>Printed in U.S.A.</p>		

Model:
THDC-8

Horizontal Dipping Cabinet: Freezer



STANDARD FEATURES

DESIGN

- True's horizontal ice cream dipping cabinets are uniquely designed to provide the user maximum functional reliability with the flexibility to both store and serve ice cream product.

REFRIGERATION SYSTEM

- Factory engineered, self-contained, capillary tube system using environmentally friendly (CFC free) R404A refrigerant.
- Cold wall refrigeration system. Maintains -10°F to +8°F (-23.3°C to -13.3°C).
- Patented reversing condenser fan motors. Fan motors reverse during defrost off cycles to help keep condenser coil free from dirt, dust and debris. Keeping coils clean optimizes the unit's performance providing colder holding temperatures and increased energy efficiency. Regularly scheduled thorough cleaning of coils still recommended.
- Condensing unit located behind rear grill on right side; slides out for easy maintenance.
- Manual defrost system; drain tube with hose connector conveniently located behind rear access panel.

CABINET CONSTRUCTION

- Exterior - non-peel or chip white laminated vinyl clad steel; durable and permanent.
- 300 series stainless steel top. The finest stainless steel for higher tensile strength for increased durability.
- Interior - high quality white enamel powder coat finish on galvanized steel. Stainless steel lid liner.
- Insulation - entire cabinet structure is foamed-in-place using Ecomate. A new, innovative, high density, polyurethane insulation that has zero ozone depletion potential (ODP) and zero global warming potential (GWP).
- Heavy duty, galvanized steel base rail with white enamel powder coat finish.

CANOPY/LIDS

- Hinged, 300 series stainless steel dipping compartment service lids with handles.
- Perimeter wiper gaskets for improved seal.
- Anti-condensate heaters reduce the potential for condensation build-up.

MODEL FEATURES

- Designed to hold nineteen (19) 9½" (242 mm) diameter, 3 gallon (12 L) ice cream containers.
- NSF-7 compliant for open food product.

ELECTRICAL

- Unit completely pre-wired at factory and ready for final connection to a 115/60/1 phase, 15 amp dedicated outlet. Cord and plug set included.



115/60/1
NEMA-5-15R

RECOMMENDED OPERATING CONDITIONS

- THDC models are designed to operate in an air conditioned environment where temperatures do not exceed 75°F and 55% relative humidity.

OPTIONAL FEATURES/ACCESSORIES

Upcharge and lead times may apply.

- 6" (153 mm) standard legs.
- 6" (153 mm) seismic/flanged legs.
- 2½" (64 mm) diameter castors.

PLAN VIEW

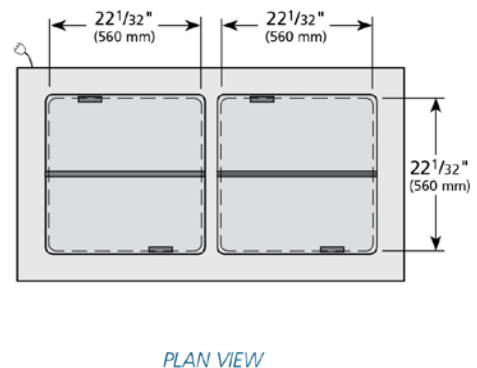
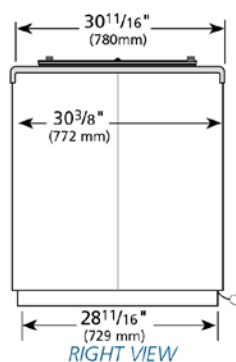
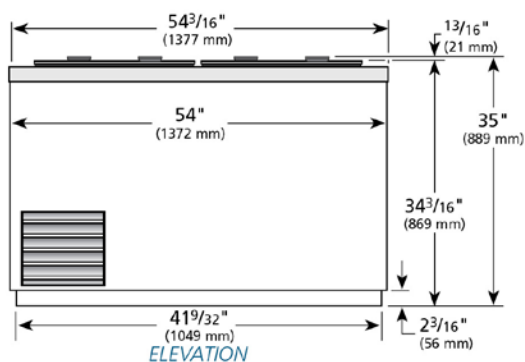

WARRANTY

One year warranty on all parts and labor and an additional 4 year warranty on compressor. (U.S.A. only)

METRIC DIMENSIONS ROUNDED UP TO THE NEAREST WHOLE MILLIMETER

SPECIFICATIONS SUBJECT TO CHANGE WITHOUT NOTICE



Model	Elevation	Right	Plan	3D	Back
THDC-8	TFM025E	TFM024S	TFM025P	TFM0253	

TRUE FOOD SERVICE EQUIPMENT