



TRUE FOOD SERVICE EQUIPMENT, INC.

2001 East Terra Lane • P.O. Box 970 • O'Fallon, Missouri 63366
 (636)240-2400 • Fax (636)272-2408 • (800)325-6152 • Intl Fax# (001)636-272-7546
 Parts Dept. (800)424-TRUE • Parts Dept. Fax# (636)272-9471 • www.truemfg.com

Project Name: _____

Location: _____

Item #: _____ Qty: _____

Model #: _____

A/A #

S/S #

Model:
TG1R-1S

TG Spec Series:
Reach-In Solid Swing Door Refrigerator



TG1R-1S

- ▶ Designed using the highest quality materials and components to provide the user with colder product temperatures, lower utility costs and exceptional food safety.
- ▶ Oversized, factory balanced, refrigeration system holds 33°F to 38°F (.5°C to 3.3°C) for the best in food preservation.
- ▶ 300 series stainless steel doors and front. Anodized quality aluminum exterior sides, back and bottom.
- ▶ NSF approved, white aluminum interior sides and back liner. 300 series stainless steel door liner and floor with coved corners.
- ▶ Adjustable, heavy duty PVC coated shelves.
- ▶ Positive seal self-closing door(s) with 120° stay open feature. Lifetime guaranteed door hinges.
- ▶ Lifetime guaranteed recessed door handle(s).
- ▶ Entire cabinet structure and solid door are foamed-in-place using Ecomate. A new, innovative, high density, polyurethane insulation that has zero ozone depletion potential (ODP) and zero global warming potential (GWP).

ROUGH-IN DATA

Specifications subject to change without notice.
 Chart dimensions rounded up to the nearest 1/8" (millimeters rounded up to next whole number).

Model	Doors	Capacity (Cu. Ft.) (liters)	Shelves	Cabinet Dimensions (inches) (mm)			HP	Voltage	Amps	NEMA Config.	Cord Length (total ft.) (total m)	Crated Weight (lbs.) (kg)
				L	D	H*						
TG1R-1S	1	31	3	29	34 5/8	78 1/4	1/3	115/60/1	8.5	5-15P	9	370
		878		737	880	1988	1/3	230-240/50/1	6.4	▲	2.74	168

* Height does not include 5" (127 mm) for castors, 6" (153 mm) for optional legs, and 1" (26 mm) for system mechanical components.

▲ Plug type varies by country.



APPROVALS:

AVAILABLE AT:

Printed in U.S.A.

Model:
TG1R-1S

TG Spec Series:
Reach-In Solid Swing Door Refrigerator



STANDARD FEATURES

DESIGN

- True's solid door reach-in's are designed with enduring quality that protects your long term investment.
- Designed using the highest quality materials and components to provide the user with colder product temperatures, lower utility costs and exceptional food safety.

REFRIGERATION SYSTEM

- Factory engineered, self-contained, capillary tube system using environmentally friendly (CFC free) 134A refrigerant.
- Extra large evaporator coil balanced with higher horsepower compressor and large condenser maintains cabinet temperatures of 33°F to 38°F (.5°C to 3.3°C) for the best in food preservation.
- Sealed, cast iron, self-lubricating evaporator fan motor(s) and larger fan blades give True reach-in's a more efficient low velocity, high volume airflow design. This unique design ensures faster temperature recovery and shorter run times in the busiest of foodservice environments.
- Top mounted refrigeration system with evaporator positioned out of food zone to maximize capacity.
- Hot gas condensate for energy efficiency.

CABINET CONSTRUCTION

- Exterior - 300 series stainless steel door(s) and rainshield. Anodized quality aluminum sides, back and bottom.
- Interior - NSF approved white aluminum side walls and back liner. 300 series stainless floor with coved corners.
- Insulation - entire cabinet structure and solid door are foamed-in-place using Ecomate. A new, innovative, high density, polyurethane insulation that has zero ozone depletion potential (ODP) and zero global warming potential (GWP).
- Welded, heavy duty steel frame rail, black powder coated for corrosion protection.
- Frame rail fitted with 4" (102 mm) diameter stem castors - locks provided on front set.

DOOR

- 300 series stainless steel exterior and liner. Door opens within cabinet dimension.
- Door lock standard.
- Lifetime guaranteed recessed door handle. Door fitted with 12" (305 mm) long recessed handle that is foamed-in-place with a sheet metal interlock to ensure permanent attachment.
- Positive seal self-closing door(s) with 120° stay open feature. Lifetime guaranteed door hinges.
- Magnetic door gasket(s) of one piece construction, removable without tools for ease of cleaning.

SHELVING

- Three (3) heavy duty PVC coated wire shelves 25" x 27³/₄" (635 mm x 705 mm). Four (4) shelf supports included per shelf (field installed). Shelves adjustable on 6" (153 mm) increments.
- Four (4) different interior kits available (see Kit Options). Pilasters and tray slides require field installation.

LIGHTING

- Incandescent interior lighting, safety shielded.

MODEL FEATURES

- Exterior digital temperature display, available with either °F or °C.
- Evaporator epoxy coated to eliminate the potential of corrosion
- NSF-7 compliant for open food product.

ELECTRICAL

- Unit completely pre-wired at factory and ready for final connection to a 115/60/1 phase, 15 amp dedicated outlet. Cord and plug set included.



115/60/1
NEMA-5-15R

OPTIONAL FEATURES/ACCESSORIES

Upcharge and lead times may apply.

- 230 - 240V / 50 Hz.
- 6" (153 mm) standard legs.
- 6" (153 mm) seismic/flanged legs.
- 6" (153 mm) stainless steel legs.
- Stainless steel rail skirt for use with legs (field installed).
- Metal door handle(s) (factory installed).
- Additional shelves.
- Electronic temperature control (factory installed).
- Correctional facilities options.
- Curb mountable units.
- Remote cabinets (condensing unit supplied by others; system comes standard with 404A expansion valve and requires R404A refrigerant). Consult factory technical service department for BTU information. All remote units must be hard wired during installation.
- Kit #1: Nine (9) sets of #1 type tray slides and pilasters (field installed), bottom support of one (1) 18"L x 26"D (458 mm x 661 mm) pan or two (2) 14"L x 18"D (356 mm x 458 mm) pans.
- Kit #2: One (1) set half-section #2 steel rod tray slides and pilasters (field installed), rim support of one (1) 18"L x 26"D (458 mm x 661 mm) pan.
- Kit #3: Six (6) sets of universal type tray slides and pilasters (field installed), bottom support of one (1) 18"L x 26"D (458 mm x 661 mm) pan, two (2) 14"L x 18"D (356 mm x 458 mm) pans or two (2) 12"L x 20"D (305 mm x 508 mm) pans.
- Kit #4: Three (3) chrome shelves 25"L x 27³/₄"D (635 mm x 705 mm). Four (4) shelf supports included per shelf (field installed); adjustable on 6" (153 mm) increments. Optional wall mounted shelf support pilasters (field installed) with four (4) shelf clips per shelf available; adjustable on 1/2" (13 mm) increments (must order at time of cabinet order).
- Additional kit option components available individually.

PLAN VIEW

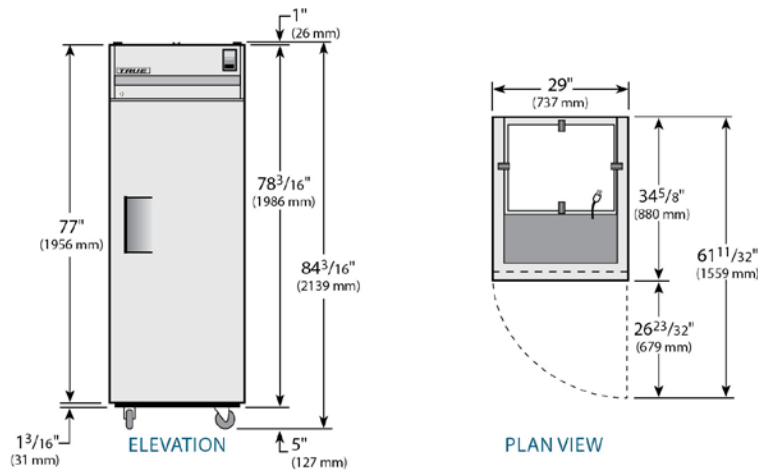

WARRANTY

One year warranty on all parts and labor and an additional 4 year warranty on compressor. (U.S.A. only)

METRIC DIMENSIONS ROUNDED UP TO THE NEAREST WHOLE MILLIMETER

SPECIFICATIONS SUBJECT TO CHANGE WITHOUT NOTICE



Model	Elevation	Right	Plan	3D	Back
TG1R-1S	TFQY50E	TFQX72S	TFQX60P	TFQX723	

TRUE FOOD SERVICE EQUIPMENT

2001 East Terra Lane • P.O. Box 970 • O'Fallon, Missouri 63366 • (636)240-2400 • Fax (636)272-2408 • (800)325-6152 • Intl. Fax# (001)636-272-7546 • www.truefmfg.com