

# Jackson

## TempStar™

Project \_\_\_\_\_  
 Item \_\_\_\_\_  
 Quantity \_\_\_\_\_  
 CSI Section 11400 \_\_\_\_\_  
 Approval \_\_\_\_\_  
 Date \_\_\_\_\_

Door Type

### Models

TempStar™



### Standard Features

- Sani-Sure™ feature assures proper rinse water temperature
- Multi-cycle timer (Extra Heavy, Heavy, Medium, Normal)
- Specially designed stainless steel nozzels provide superior cleaning action
- 17-1/4" (438 mm) door opening accepts 18" (457 mm) trays
- Interchangeable wash/rinse arms screw out for simple cleanup
- Auto-fill / auto-start
- Safety door switch
- Delime/manual wash switch
- Low watt density electric wash tank heater
- Hi-limit thermostat and low water protection
- Top mounted controls for ease of installation
- Adjustable bullet feet
- Uses standard 20" X 20" (508 mm X 508 mm) racks
- Front dress panel
- Detergent/rinse additive signal connection fuse box
- Self-draining stainless steel pump
- Built-in 70° F (21° C) rise booster heater is standard; 40° F (4° C) rise booster heater is available but must be specified at time of order
- Large scrap tray

### Mandatory Specs

- Specify voltage
- Specify booster size
- Specify electric or steam heat

### Optional Features

- Optional 40° F (4° C) rise booster heater is available at no additional cost (must be specified)
- Drain quench system
- Scaltrol
- Water hammer arrestor
- Flanged feet

### Accessories

- 36" (914 mm) compartment rack 4-1/6" (4 mm) tall
- 36" (914 mm) compartment rack 5-5/8" (16 mm) tall
- 36" (914 mm) compartment rack 7" (178 mm) tall
- Combination rack
- Peg rack

### Specifications

Uses .89 gallons (3 liters) of water per rack

Total automatic (normal) cycle - 57 seconds

58 racks per hour (normal) cycle

3/4 HP Wash Pump Motor

Single point connections for all utilities

Built-in water pressure regulator and gauge

Field convertible from straight through to corner application

Heavy duty stainless steel construction



**SHIPPING ADDRESS**  
 6209 North U.S. Highway 25E  
 Gray, KY 40734

**MAILING ADDRESS**  
 P. O. Box 1060  
 Barbourville, KY 40906

**Tel: 606-523-9795**  
**Tel: 1-888-800-5672**  
**Fax: 606-523-1799**

**www.jacksonmsc.com**  
**E-mail: customerservice@jacksonmsc.com**  
**07610-002-66-59 (04/09)**



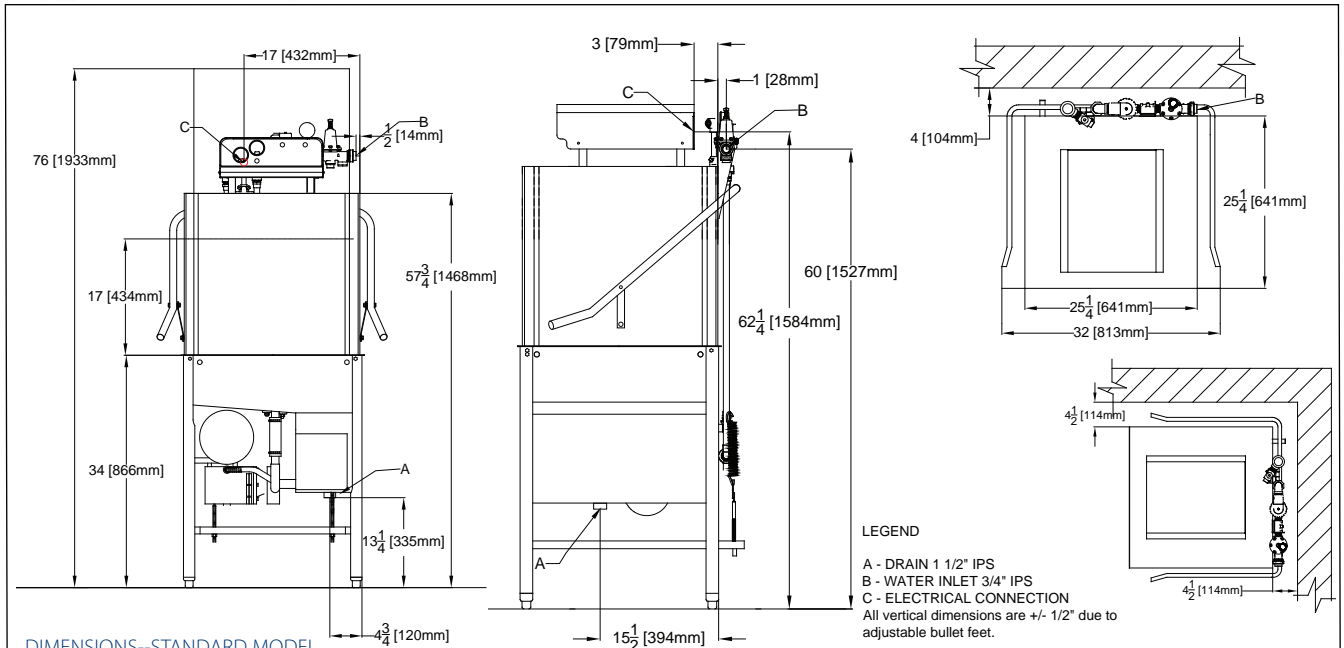

DIMENSIONS--STANDARD MODEL

MODEL NO.	SIZE			DRAIN HEIGHT	SHIPPING INFO			DIMENSIONS		
	HEIGHT	WIDTH	DEPTH		WEIGHT	CLASS	CUBE	HEIGHT	WIDTH	DEPTH
TempStar™	64-3/8" (1635 mm)	25-1/4" (641 mm)	25-1/4" (641 mm)	13-1/4" (335 mm)	350 lbs (159 kg)	92.5	37-1/2 cu. ft.	72" (1829 mm)	30" (762 mm)	30" (762 mm)

DIMENSION REQUIREMENTS

Wall Clearance (Minimum)	4" / (102 mm)
Standard Table Height	34" / (864 mm)
Inside Clearance	17-1/4" / (438 mm)

STEAM REQUIREMENTS

Steam Flow Pressure (PSIG)	15-20
Consumption @ 15 PSIG (lbs./hr.)	45

OPERATING CAPACITY

Racks per Hour	Normal 58	Medium 30	Heavy 20	Extra Heavy 12
OPERATING CYCLE (sec)	Wash	Rinse	Dwell	Total Cycle
Normal	40	13	4	57
Medium	100	13	4	117
Heavy	160	13	4	177
Extra Heavy	280	13	4	297

WATER REQUIREMENTS

Inlet Temperature	
40°F / (4°C) Rise	140°F / (82°C)
70°F / (21°C) Rise	110°F / (60°C)
Gallons per Hour	52 / (197 ltr)
Gallons per Rack	.89 / (3 ltr)
Waterline Size IPS (Minimum-inches)	1/2
Drainline Size IPS (Minimum-Inches)	1-1/2
Flow Pressure (PSI)	10
Wash Tank Capacity	8 Gal. / (30 ltr)
Booster Tank Capacity	3 Gal. / (11 ltr)

OPERATING TEMPERATURES

Wash (Minimum)	150°F / (66°C)
Rinse (Minimum)	180°F / (82°C)

WASH PUMP MOTOR

Wash Pump Motor Horsepower	3/4 HP
----------------------------	--------

APPROXIMATE LOAD AMPS

Power Supply	40°F (4°C) Rise	70°F (21°C) Rise
208V/60HZ/1PH	68.7	75.8
208V/60HZ/3PH	42.1	46.3
230V/60HZ/1PH	75.4	83.6
230V/60HZ/3PH	45.5	50.7
460V/60HZ/3PH	21.7	24.1

	Volts	KW
Electric Wash Tank Heater	208V	4.1
	230V	5.0
	460V	5.0
Electric Rinse Tank Heater 40°F (4°C) Rise	208V	9.0
	230V	11.0
	460V	11.0
70°F (21°C) Rise	208V	10.5
	230V	12.9
	460V	12.9

How To Specify - TempStar™

**SHIPPING ADDRESS**  
 6209 North U.S. Highway 25E  
 Gray, KY 40734

**MAILING ADDRESS**  
 P. O. Box 1060  
 Barbourville, KY 40906

**Tel: 606-523-9795**  
**Tel: 1-888-800-5672**  
**Fax: 606-523-1799**

**www.jacksonmsc.com**  
**E-mail: customerservice@jacksonmsc.com**  
**07610-002-66-59 (04/09)**

