



**TRUE FOOD SERVICE
EQUIPMENT, INC.**

2001 East Terra Lane • P.O. Box 970 • O'Fallon, Missouri 63366
(636)240-2400 • Fax (636)272-2408 • (800)325-6152 • Intl Fax# (001)636-272-7546
Parts Dept. (800)424-TRUE • Parts Dept. Fax# (636)272-9471 • www.truemfg.com

Project Name: _____

Location: _____

Item #: _____ Qty: _____

Model #: _____

A/A #

S/S #

Model:
TDC-47-CG

Curved Glass Front Dipping Cabinet:
Freezer



TDC-47-CG

- ▶ True's visual dipping cabinets are uniquely designed to provide the user maximum functional reliability in an attractive merchandiser to brilliantly display and serve ice cream product.
- ▶ Cold wall refrigeration system. Maintains -10°F to +8°F (-23.3°C to -13.3°C).
- ▶ Patented reversing condenser fan motors. Fan motors reverse during defrost off cycles to help keep condenser coil free from dirt, dust and debris. Keeping coils clean optimizes the unit's performance providing colder holding temperatures and increased energy efficiency. Regularly scheduled thorough cleaning of coils still recommended.
- ▶ Heavy-duty, PVC coated wire can support racks. Positions the open ice cream containers on top level to optimum service height. Lower level provides for extra can storage.
- ▶ Designed to hold eight (8) 9 ½" (242 mm) diameter, 3 gallon (12 L) ice cream containers in display area and four (4) on floor beneath support racks.
- ▶ Eight (8) removable, molded plastic can skirts for 9 ½" (242 mm) diameter, 3 gallon (12 L) cans. Firmly holds cans in place and provides attractive, neat appearance.
- ▶ White, 6" (153 mm) wide, NSF approved, removable magnetic frost shields. Provides for easy clean up and removal of ice build-up on cabinet walls.
- ▶ Two (2) white plastic night covers for case opening.
- ▶ Entire cabinet structure is foamed-in-place using Ecomate. A new, innovative, high density, polyurethane insulation that has zero ozone depletion potential (ODP) and zero global warming potential (GWP).

ROUGH-IN DATA

Specifications subject to change without notice.
Chart dimensions rounded up to the nearest 1/8" (millimeters rounded up to next whole number).

Model	Lids	Capacity		Racks	Cabinet Dimensions (inches) (mm)			HP	Voltage	Amps	NEMA Config.	Cord Length (total ft.) (total m)	Crated Weight (lbs.) (kg)
		(Cu. Ft.) (liters)	3 gal. 12 L Cans		L	D	H						
TDC-47-CG	1	12.7 360	12	4	46¾ 1188	27¾ 696	52¾ 1318	1/3	115/60/1	6.7	5-15P	9 2.74	390 177



Printed in U.S.A.

APPROVALS:

AVAILABLE AT:

Model:
TDC-47-CG

Curved Glass Front Dipping Cabinet: Freezer



STANDARD FEATURES

DESIGN

- True's visual dipping cabinets are uniquely designed to provide the user maximum functional reliability in an attractive merchandiser to brilliantly display and serve ice cream product.

REFRIGERATION SYSTEM

- Factory engineered, self-contained, capillary tube system using environmentally friendly (CFC free) R404A refrigerant.
- Cold wall refrigeration system. Maintains -10°F to +8°F (-23.3°C to -13.3°C).
- Patented reversing condenser fan motors. Fan motors reverse during defrost off cycles to help keep condenser coil free from dirt, dust and debris. Keeping coils clean optimizes the unit's performance providing colder holding temperatures and increased energy efficiency. Regularly scheduled thorough cleaning of coils still recommended.
- Condensing unit located behind rear grill on right side; slides out for easy maintenance.
- Manual defrost system; drain tube with hose connector conveniently located behind rear access panel.

CABINET CONSTRUCTION

- Exterior - non-peel or chip white laminated vinyl clad steel; durable and permanent.
- 300 series stainless steel top with raised rim protects cabinet and helps minimize spillage to keep cabinet interior clean.
- Interior - high quality white enamel powder coat finish on galvanized steel.
- Insulation - entire cabinet structure is foamed-in-place using Ecomate. A new, innovative, high density, polyurethane insulation that has zero ozone depletion potential (ODP) and zero global warming potential (GWP).
- Heavy duty, galvanized steel base rail with white enamel powder coat finish.

CANOPY/LIDS

- Stainless steel frame with tempered, single pane, curved glass viewing window.
- Hinged, transparent acrylic dipping compartment service lid with full length handle. Top and back wiper gaskets for improved seal.

SUPPORT RACKS

- Four (4) heavy-duty, PVC coated wire can support racks 7" x 20½" (178 mm x 521 mm). Positions the open ice cream containers on top level to optimum service height.
- Each rack designed to hold two (2) 9½" (242 mm) diameter, 3 gallon (12 L) ice cream containers.
- Lower level beneath support racks provides for extra can storage of four (4) 9½" (242 mm) diameter, 3 gallon (12 L) ice cream containers.

LIGHTING

- Safety shielded, fluorescent interior canopy lighting for brighter, shadow free illumination. Independent on/off switch.
- Cabinet lighting utilizes electronic ballast and T-8 bulbs for brighter illumination, longer bulb life and increased energy efficiency.

MODEL FEATURES

- White, 6" (153 mm) wide, NSF approved, removable magnetic frost shields. Provides for easy clean up and removal of ice build-up on cabinet walls.
- Two (2) white plastic night covers for case opening.
- Eight (8) removable, molded plastic can skirts for 9½" (242 mm) diameter, 3 gallon (12 L) cans. Firmly holds cans in place and provides attractive, neat appearance.
- NSF-7 compliant for open food product.

ELECTRICAL

- Unit completely pre-wired at factory and ready for final connection to a 115/60/1 phase, 15 amp dedicated outlet. Cord and plug set included.



115/60/1
NEMA-5-15R

RECOMMENDED OPERATING CONDITIONS

- TDC models are designed to operate in an air conditioned environment where temperatures do not exceed 75°F and 55% relative humidity.
- Units should be installed away from direct sunlight, rapid air movement and extreme temperature changes.

OPTIONAL FEATURES/ACCESSORIES

Upcharge and lead times may apply.

- 6" (153 mm) standard legs.
- 6" (153 mm) seismic/flanged legs.
- 2½" (64 mm) diameter castors.
- Dipper well kit (NSF approved).
- Lid locking kit (lock not included).

PLAN VIEW

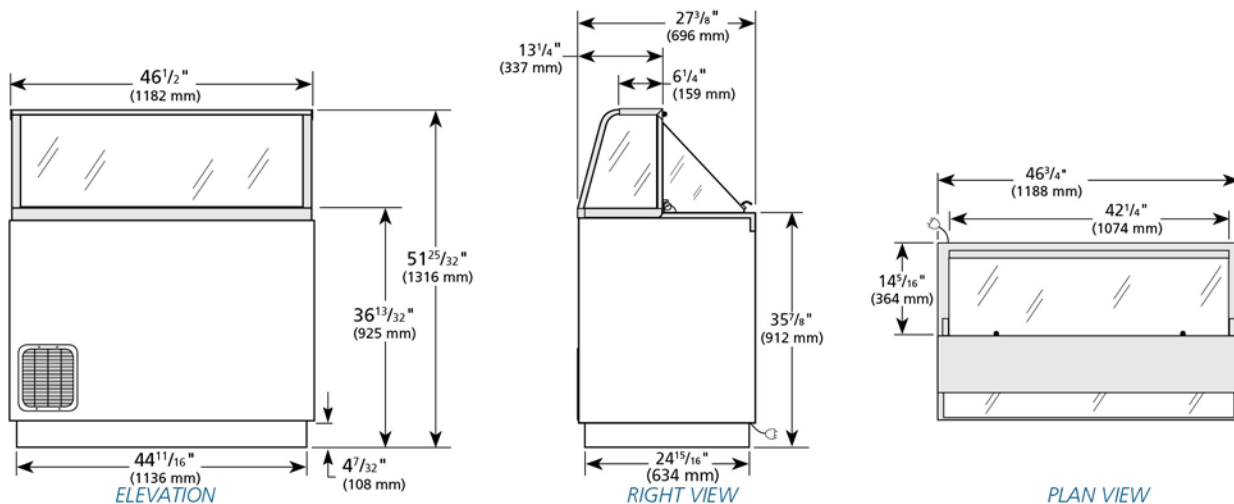

WARRANTY

One year warranty on all parts and labor and an additional 4 year warranty on compressor. (U.S.A. only)

METRIC DIMENSIONS ROUNDED UP TO THE NEAREST WHOLE MILLIMETER

SPECIFICATIONS SUBJECT TO CHANGE WITHOUT NOTICE



Model	Elevation	Right	Plan	3D	Back
TDC-47-CG					

TRUE FOOD SERVICE EQUIPMENT