



TRUE FOOD SERVICE EQUIPMENT, INC.

2001 East Terra Lane • P.O. Box 970 • O'Fallon, Missouri 63366
(636)240-2400 • Fax (636)272-2408 • (800)325-6152 • Intl Fax# (001)636-272-7546
Parts Dept. (800)424-TRUE • Parts Dept. Fax# (636)272-9471 • www.truemfg.com

Project Name: _____

Location: _____

Item #: _____ Qty: _____

Model #: _____

A/A #

SIS #

Model:
TCGR-77

Display Case: *Curved Glass Refrigerated Bakery Case*



TCGR-77

- ▶ True's refrigerated bakery case combines efficient, high volume merchandising and exceptional refrigeration with an elegant curved glass front for sophisticated presentation of high end desserts and pastries.
- ▶ Self-contained, environmentally friendly (CFC free) 134A refrigeration system.
- ▶ More efficient low velocity, high volume airflow design maintains 38°F to 40°F (3.3°C to 4.4°C) without drying out product. Ideally suited for delicate bakery products.
- ▶ Cabinet is NSF-7 certified to hold open food product.
- ▶ Insulated, double pane curved glass front and side glass panels provide extra large viewing area to maximize bakery product presentation. Front glass tilts forward for easy cleaning.
- ▶ Three (3) adjustable PVC coated shelves.
- ▶ Fluorescent lamps are low UV emitting to enhance product appearance and increase shelf life.
- ▶ Exterior front and sides standard with white laminate panels, five additional color options available at no charge. Stainless steel top.
- ▶ White aluminum interior sides and top. High impact plastic floor with coved corners.

ROUGH-IN DATA

Specifications subject to change without notice.

Chart dimensions rounded up to the nearest 1/8" (millimeters rounded up to next whole number).

| Model | Doors | Capacity (Cu. Ft.) (liters) | Shelves | Cabinet Dimensions (inches) (mm) | | | HP | Voltage | NEMA Config. | Amps | Crated Weight (lbs.) (kg) |
|---------|-------|-----------------------------------|---------|--|---------------------------------------|--|-----------------------------|----------|-----------------|------|------------------------------------|
| | | | | L | D [†] | H | | | | | |
| TCGR-77 | 2 | 43 1218 | 3 | 77 ⁷ / ₈ 1979 | 35 ¹ / ₂ 902 | 47 ⁷ / ₈ 1217 | ³ / ₄ | 115/60/1 | 5-20P | 15.3 | 820 372 |

[†] Depth does not include 3/4" (18 mm) for door handles.

6/07 Printed in U.S.A.

APPROVALS:

AVAILABLE AT:

Model:
TCGR-77

Display Case:
Curved Glass Refrigerated Bakery Case



STANDARD FEATURES

DESIGN

- True's refrigerated bakery case combines efficient, high volume merchandising and exceptional refrigeration with an elegant curved glass front for sophisticated presentation of high end desserts and pastries.
- Designed to provide an attractive companion to our "dry" display case.

REFRIGERATION SYSTEM

- Factory engineered, self-contained, capillary tube system using environmentally friendly (CFC free) 134A refrigerant.
- Extra large evaporator coil balanced with higher horsepower compressor and large condenser maintains 38°F to 40°F (3.3°C to 4.4°C), ideally suited for bakery products.
- Forced-air refrigeration system; sealed, cast iron, self-lubricating evaporator fan motor(s) and larger fan blades give True refrigerated bakery cases a more efficient low velocity, high volume airflow design.
- Condensing unit located behind removable panel in back of unit. Entire system slides out for easy cleaning and maintenance.

CABINET CONSTRUCTION

- Exterior - white laminate front and side panels. Color options available at no charge:



Walnut | Teak | Oak | Beige | Black | White

All laminate ships separately from unit and is field installed. Stainless steel top. Black front grill and trim. Template kit available at no charge for field customization of laminate.

- Interior - NSF approved white aluminum sides and top; high impact plastic floor with coved corners.

- Insulation - entire cabinet structure is foamed-in-place using high density, CFC free, polyurethane insulation.
- Welded, heavy duty galvanized frame rail dipped in rust inhibiting enamel paint for corrosion protection inside and out.
- Frame rail fitted with leg levellers.

CURVED FRONT DISPLAY GLASS

- Insulated, double pane curved glass front and side panels provide extra large viewing area to maximize bakery product presentation. Exterior pane is tempered for safety.
- Front glass tilts forward for easy cleaning.

REAR DOORS

- "Low-E", double pane thermal glass rear door inserts with mitered plastic channel frames.
- Each door fitted with 12" (305 mm) long molded plastic handle.
- Self-closing doors, efficient counter balanced weight system for smooth, even, positive closure. Sliding doors ride on stainless steel V-channel with stainless steel bearings. Doors fit within plastic channel frame.

SHELVING

- Three (3) adjustable, lighted, heavy duty PVC coated wire shelves 71³/₈" L x 22¹/₂" D (1813 mm x 572 mm). Shelving system is cantilevered and angle can be adjusted to maximize presentation.
- Each shelf supports a maximum weight of 150 lbs. (69 kg).

PAN CAPACITY

- Cabinet holds sixteen (16) 18" L x 26" D (458 mm x 661 mm) display pans (4 per level). Pans supplied by others.

LIGHTING

- Cabinet equipped with four (4) light sources for maximum product display; three (3) shelf mounted and one (1) cabinet mounted.

Fluorescent lamps are low UV emitting to enhance product appearance and increase shelf life.

- Safety shielded lighting tubes assure longer, brighter, shadow-free product illumination.

MODEL FEATURES

- Evaporator is epoxy coated to eliminate the potential of corrosion.
- Recessed exterior light switch and thermostat control.
- NSF-7 compliant for open food product.

ELECTRICAL

- Unit completely pre-wired at factory and ready for final connection to a 115/60/1 phase - 20 amp dedicated outlet. Cord and plug set included.



115/60/1
NEMA-5-20R

RECOMMENDED OPERATION CONDITIONS

- TCGR models are designed to operate in an environment where temperature and humidity do not exceed 75°F (24°C) and 55% relative humidity.

OPTIONAL FEATURES/ACCESSORIES

Upcharge and lead times may apply.

- Custom exterior laminates, contact factory for details. See our website: www.truemfg.com for the latest color offerings.
- Stainless steel exterior.
- Mirrored interior ends with laminate exterior.
- Additional lighted shelves.
- Additional non-lighted shelves.
- Remote cabinets (condensing unit supplied by others; system comes standard with 404A expansion valve and requires R404A refrigerant). Consult factory technical service department for BTU information.

PLAN VIEW

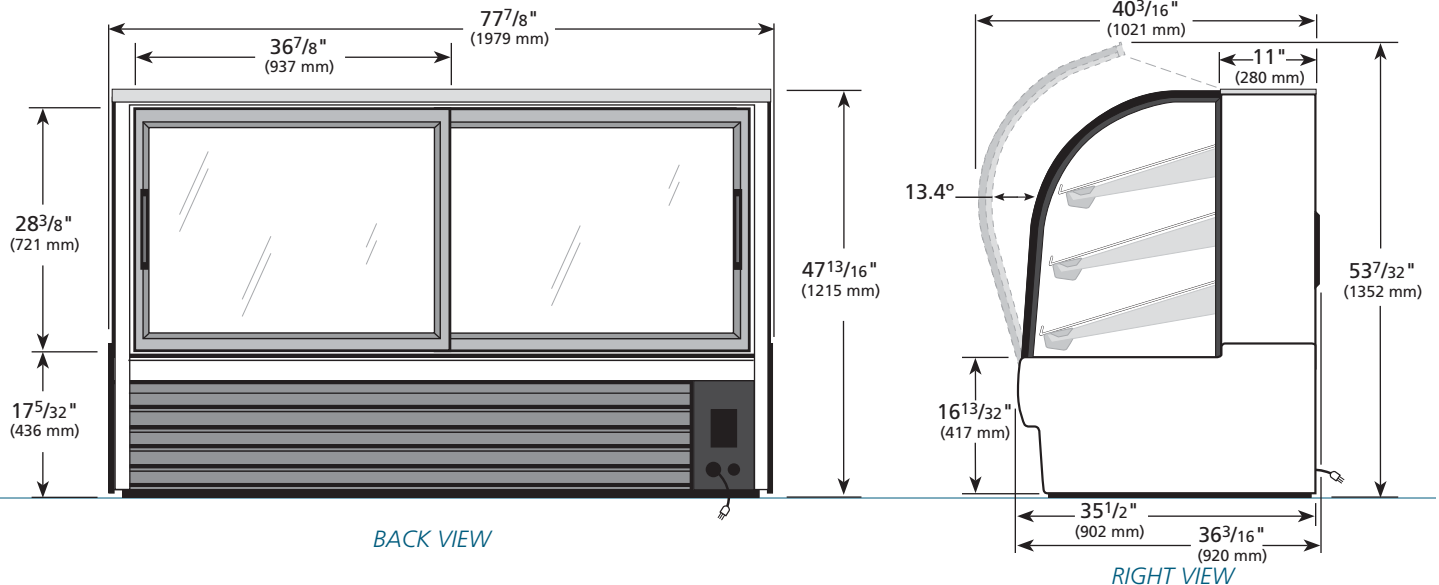

WARRANTY
One year warranty on all parts & labor and an additional 4 year warranty on compressor. (U.S.A. only)

METRIC DIMENSIONS ROUNDED UP TO THE NEAREST WHOLE MILLIMETER
SPECIFICATIONS SUBJECT TO CHANGE WITHOUT NOTICE



| Model | Elevation | Right | Plan | 3D | Back |
|---------|-----------|---------|---------|---------|---------|
| TCGR-77 | TFD067E | TFD055S | TFD066P | TFD0663 | TFD066B |

TRUE FOOD SERVICE EQUIPMENT