



TRUE FOOD SERVICE EQUIPMENT, INC.

St. Charles Industrial Center • P.O. Box 970 • O'Fallon, Missouri 63366
 (636)240-2400 • FAX (636)272-2408 • (800)325-6152 • www.truemfg.com
 Parts Dept. (800)424-TRUE • Parts Dept. FAX# (636)272-9471

Project Name: _____

A/A #

Location: _____

Item #: _____ Qty: _____

SIS #

Model #: _____

Model:
TCGR-77-CD

Display Case:
Curved Glass Refrigerated Cold Deli Case



TCGR-77-CD

- ▶ True's refrigerated cold deli case combines efficient, high volume merchandising and exceptional refrigeration with an elegant curved glass front for sophisticated presentation of deli products.
- ▶ Self-contained, environmentally friendly (CFC free) 134A refrigeration system.
- ▶ More efficient low velocity, high volume airflow design maintains 36°F to 38°F (2.2°C to 3.3°C) without drying out product. Ideally suited for deli meats and cheeses.
- ▶ Cabinet is NSF-7 certified to hold open food product.
- ▶ Insulated, double pane curved glass front and side glass panels provide extra large viewing area to maximize deli product presentation. Front glass tilts forward for easy cleaning.
- ▶ One (1) adjustable, lighted, mezzanine shelf.
- ▶ Low UV emitting fluorescent lighting system.
- ▶ Front and sides standard with white laminate panels, five additional color options available at no charge. Stainless steel top.

ROUGH-IN DATA

Specifications subject to change without notice.

Chart dimensions rounded up to the nearest 1/8" (millimeters rounded up to next whole number).

Model	Doors	Capacity (Cu. Ft.) (liters)	Shelves	Cabinet Dimensions (inches) (mm)			HP	Voltage	Amps	NEMA Config.	Cord Length (total ft.) (total m)	Crated Weight (lbs.) (kg)
				L	D	H						
TCGR-77-CD	2	37.2 1218	1	77 ⁷ / ₈ 1979	35 ¹ / ₂ 902	47 ⁷ / ₈ 1217	³ / ₄	115/60/1	15.5	5-20P	9 2.74	N/A

9/05 Printed in U.S.A.

APPROVALS:

AVAILABLE AT:

Model:
TCGR-77-CD

Display Case:
Curved Glass Refrigerated Cold Deli Case



STANDARD FEATURES

DESIGN

- True's refrigerated cold deli case combines efficient, high volume merchandising and exceptional refrigeration with an elegant curved glass front for sophisticated presentation of deli products.
- Designed to provide an attractive companion to our "refrigerated" and "dry" display cases.

REFRIGERATION SYSTEM

- Factory engineered, self-contained, capillary tube system using environmentally friendly (CFC free) 134A refrigerant.
- Extra large evaporator coil balanced with higher horsepower compressor and large condenser maintains 36°F to 38°F (2.2°C to 3.3°C), ideally suited for deli meats and cheeses.
- Forced-air refrigeration system; sealed, cast iron, self-lubricating evaporator fan motor and larger fan blades give True refrigerated display cases a more efficient low velocity, high volume airflow design.
- Condensing unit located behind removable panel in back of unit; slides out for easy cleaning and maintenance.

CABINET CONSTRUCTION

- Exterior - white laminate front and side panels. Color options available at no charge:



Walnut | Teak | Oak | Beige | Black | White
All laminate ships separately from unit and is field installed. Stainless steel top. Black front and rear grills and trim.

- Interior - 300 series stainless steel sides and top; high impact plastic floor with coved corners.

- Insulation - entire cabinet structure is foamed-in-place using high density, CFC free, polyurethane insulation.
- Welded, heavy duty galvanized frame rail dipped in rust inhibiting enamel paint for corrosion protection inside and out.
- Frame rail fitted with leg levelers.

CURVED FRONT DISPLAY GLASS

- Insulated, double pane curved glass front and side panels provide extra large viewing area to maximize product presentation. Exterior pane is tempered for safety.
- Front glass tilts forward for easy cleaning.

REAR DOORS

- "Low-E", double pane thermal glass insert with a mitered plastic channel frame.
- Each door fitted with 12" (305 mm) long molded plastic handle.
- Self-closing doors, efficient counter balanced weight system for smooth, even, positive closure. Sliding doors ride on stainless steel V-channel with stainless steel bearings. Doors fit within plastic channel frame.

SHELVING

- One (1) adjustable, cantilevered lighted, stainless mezzanine shelf 18³/₁₆" L x 73¹¹/₁₆" D (462 mm x 1872 mm).
- Shelf supports a maximum weight of 150 lbs. (69 kg).

LIGHTING

- Cabinet is equipped with 2 light sources for product display; (1) shelf mounted and (1) cabinet mounted. Fluorescent lamps are low UV emitting to enhance product appearance and increase shelf life.
- Safety shielded lighting tube assure longer, brighter, shadow-free product illumination.

MODEL FEATURES

- Evaporator is epoxy coated to eliminate the potential of corrosion.
- Recessed exterior light switch and thermostat control.
- NSF-7 compliant for open food product.

ELECTRICAL

- Unit completely pre-wired at factory and ready for final connection to a 115/60/1 phase - 20 amp dedicated outlet. Cord and plug set included.



115/60/1
NEMA-5-20R

RECOMMENDED OPERATION CONDITIONS

- TCGR models are designed to operate in an environment where temperature and humidity do not exceed 75°F (24°C) and 55% relative humidity.

OPTIONAL FEATURES/ACCESSORIES

Upcharge and lead times may apply.

- Custom exterior laminates, contact factory for details. See our website: www.truemfg.com for the latest color offerings.
- Ratchet lock.
- Additional lighted stainless steel mezzanine shelves.
- Non-lighted stainless steel mezzanine shelves.
- Remote cabinets (condensing unit supplied by others), consult factory technical service department for BTU information.

PLAN VIEW

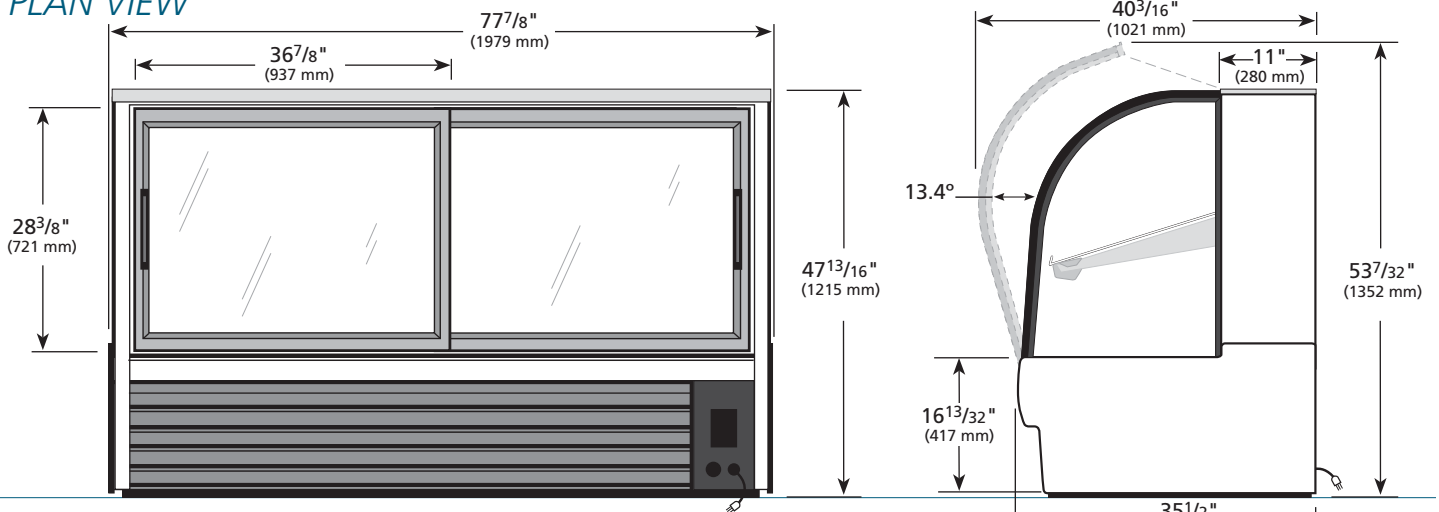

WARRANTY
One year warranty on all parts & labor and an additional 4 year warranty on compressor. (U.S.A. only)

METRIC DIMENSIONS ROUNDED UP TO THE NEAREST WHOLE MILLIMETER
SPECIFICATIONS SUBJECT TO CHANGE WITHOUT NOTICE

	Model	Elevation	Right	Plan	3D	Back
	TCGR-77-CD					

TRUE FOOD SERVICE EQUIPMENT