

MAJOR MIXER MX91

THE RIGHT TOOLS

PERFORMANCE

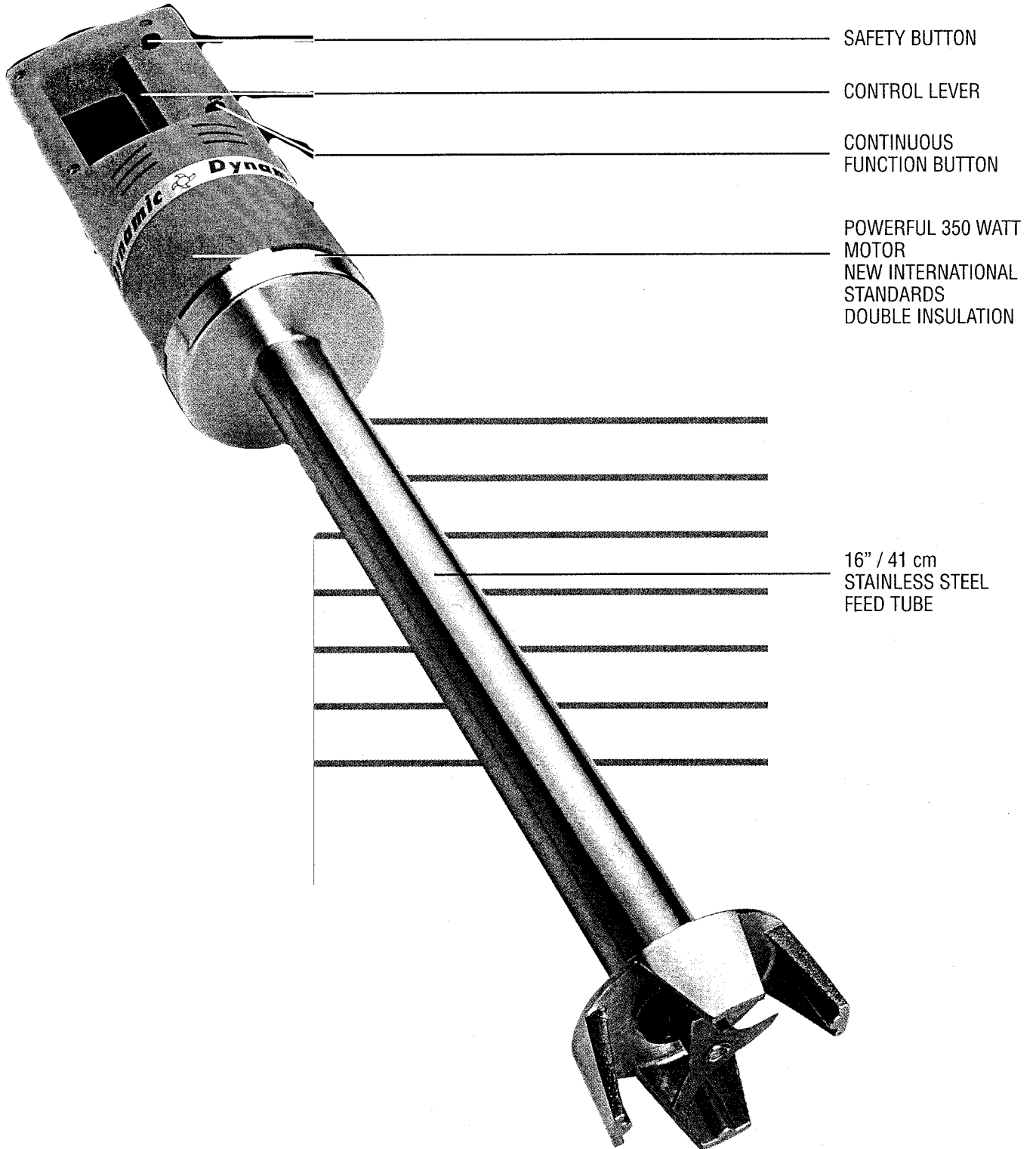

Dynamic
EXPERIENCE IN THE SERVING OF PROFESSIONAL

MAJOR MIXER MX91

PROFESSIONAL KITCHENS

Restaurants • Canteens • Communal dining areas

PERFORMANCE:

- The **MX91 MIXER** is light and easy to handle, a powerful piece of equipment designed to be used in cooking pots holding up to **25 gallons / 100 litres**.
- It will blend 12 gallons / 50 litres of cooked vegetable soup in under 3 minutes, including stringy vegetables such as leeks and celery. It is likewise recommended for difficult tasks such as fish soup.

MAINTENANCE AND HYGIENE:

- The plunger tube, made entirely of stainless steel, can be washed in clear water in a few seconds **WITHOUT REMOVING ANYTHING**.
- No greasing or special maintenance is necessary. Wall brackets make it easy to put away so that it takes up a minimum of space in your kitchen.

RELIABILITY:

- The **DYNAMIC MX91 MIXER** has been designed for professional kitchens : ergonomic, robust and powerful, its **UNITARY** design ensures that it will withstand intensive use without defects over many years.
- The length of the plunger tube (41 cm / 16") safeguards it against the dangers of immersion and projection.

VARIOUS USES:

- Allows you to mix and blend excellent veloute soups directly in the cooking pot, as well as : fish soup, bread soup, vegetable soups, spinach, salads, chopped cabbage, pancake mixture, mayonnaise etc...

- For the nursery and special diets : finely puréed vegetables, clear soups, puréed raw carrot, fruit creams etc...
- Can also be very useful in certain industries : perfume manufacture, iron foundry, dyeing plant, ceramics, laboratories, dressing works etc...

IMPORTANT RECOMMENDATIONS:

- To obtain maximum efficiency, we recommend that the mixer is held obliquely without resting the protective cover on the bottom of the cooking pot, as shown in the sketches below :

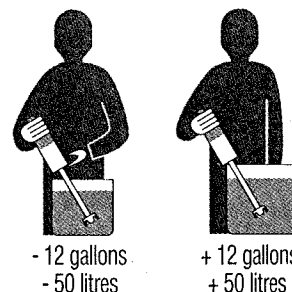

- By following the recommendations, you will not risk immersing the motor. The **life expectancy** of your mixer depends on this.

CHARACTERISTICS:

- Motor 120 Volts
(220 Volts on request)
- Power consumed 350 Watts
- Speed in use 8 300 Rpm
- Immersable tube length 16" / 41 cm
- Total length 28 1/4" / 71.5 cm
- Weight : 9 lbs / 4 kg

- This mixer is equipped with **double insulation** in accordance with safety standards.

CANADA
5859 Chemin Saint-François
Ville Saint-Laurent, Qc
Canada H4S 1B6
USA
P.O. Box 1798
1320 Route 9
Champlain, N.Y. 12919

TOLL FREE:
PHONE: 1-800-267-7794
or: 1-877-668-6622
FAX: 1-877-668-6623

LOCAL:
PHONE: (514) 956-0127
FAX: (514) 956-8983

 **Dynamic**
EXPERIENCE IN THE SERVING OF PROFESSIONAL